

**MB&F**

**HOROLOGICAL MACHINE N°12 THE GUARDIAN**

## **The Watch**

**P. 6-7 Your watch**

**P. 8-9 Time setting**

**P. 10-11 Winding**

**P. 12-13 Face shield**

**P. 14-15 Quick release strap**

## **The Robot**

**P. 18-21 Care and maintenance**

**P. 22-23 Meet your robot**

**P. 24-25 Robot set-up and removal**

**P. 26-27 Push-to-open drawer**

**P. 28-29 UV lamp**

**P. 30-31 Magnifying glass**

**P. 32-33 Thermometer**

**P. 34-35 Thermometer setup**

**P. 36-37 Crest / watch support**

**P. 38-39 Moving the arms**

HOROLOGICAL MACHINE N°12 THE GUARDIAN  
THE WATCH

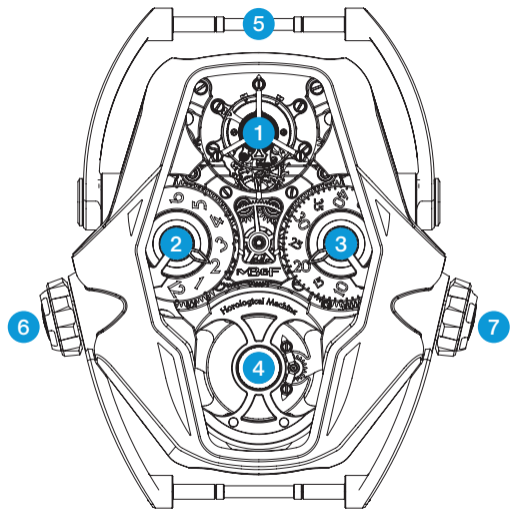

Your watch

1. Tourbillon
2. Hour-disc
3. Minute-disc
4. Rotor
5. Mobile attachment
6. Shield opening/closing crown
7. Time adjustment and winding crown

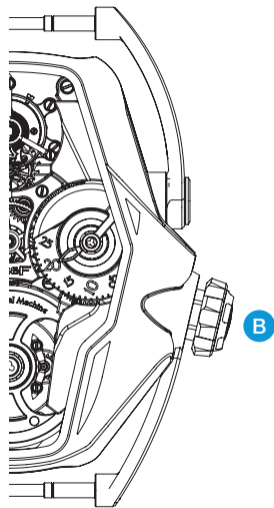
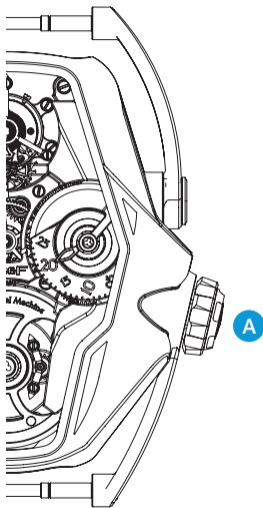

### Time setting

First, pull the crown (A) to the “out” position (B), and turn it to set the time.  
Push the crown back against the case.

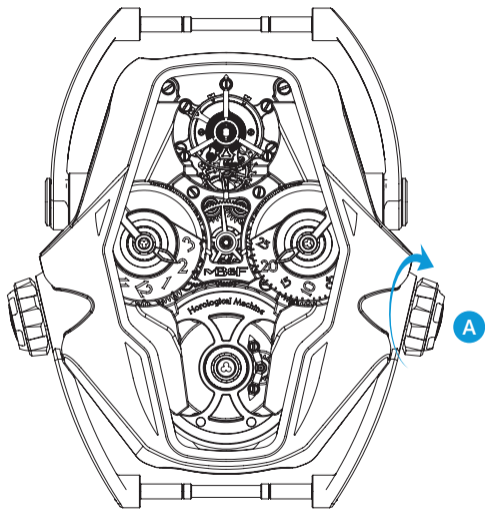

## Winding

Your watch is equipped with an automatic movement. If it has stopped, to wind the watch, turn the time setting and winding crown (A) clockwise several times.

Visible shield

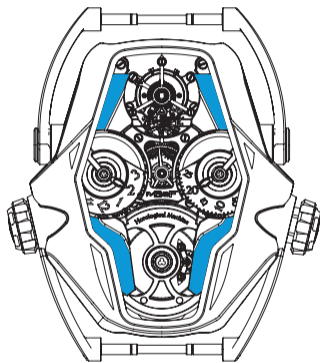

Hidden shield

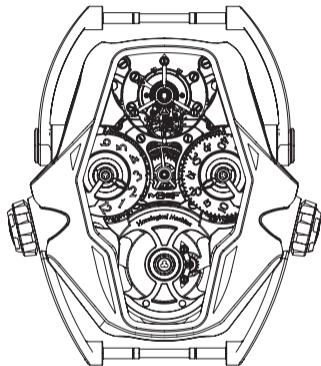

Face shield

Use the left-hand crown (A) to open or close the watch's shield. Simply turn the crown back and forth in order to make the shield visible (B) or hide (C) the decorative face armor.

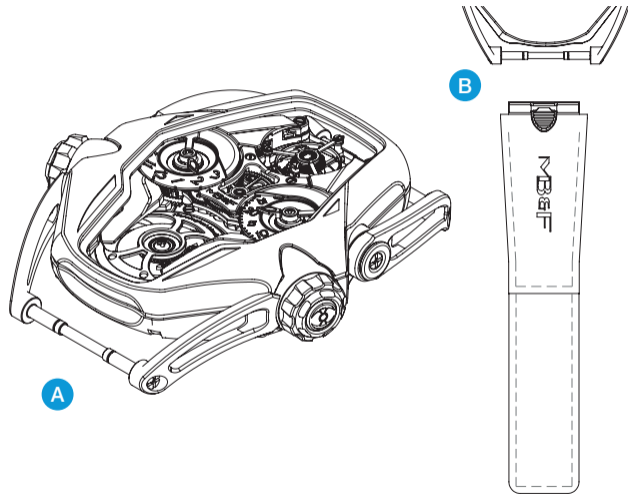

### Quick release strap Removal and setup

Your watch benefits from a quick release system offering an easy strap removal and setup. To remove your strap in order to place your watch on your HM12 robot's head, simply press the push-button on the back of the strap towards the outer end (not towards the watch). Then just slide it off while taking great care not to let it slip.

The same procedure applies on both sides of the watch for both strap ends.

See page 34 for instructions on installing the watch on the robot.

HOROLOGICAL MACHINE N°12 THE GUARDIAN  
THE ROBOT

### Important information

Your HM12 Robot's base is highly magnetic in order to keep your robot stable and secured. Please keep watches clear of its surface and ensure a distance of at least 10 centimeters from your watches when handling your HM12 stand.

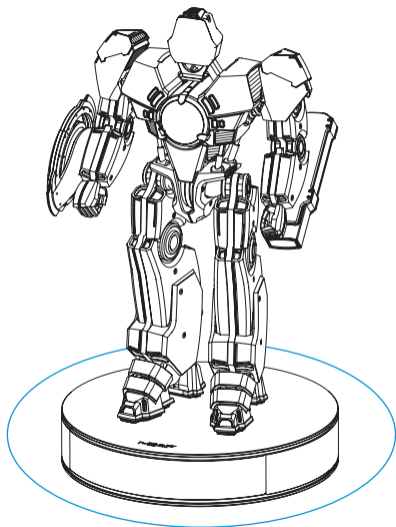

### Care and maintenance

Use only a soft and dry cloth to clean the robot. Please be aware that dust and particles contained in the cloth could scratch parts - keep the cloth clean at all times. Do not use any kind of cleaning products to wipe the robot. Fingerprints could also damage the coating so always wear gloves when manipulating the robot and wipe out any fingerprints with a soft cloth.

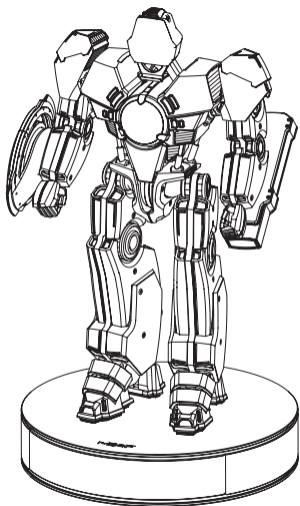
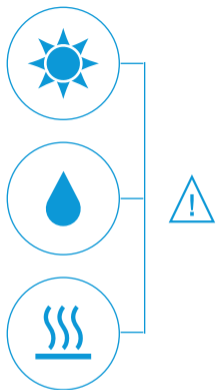

## Care and maintenance

Your HM12 robot is delicate, please make sure that it is placed in a safe environment, away from strong movement. It is recommended to keep the robot distant from any source of heat or vibrations. To preserve the longevity and functionality of your HM12 The Guardian, do not permanently expose the robot to direct sunlight or in a humid or dusty place. Be careful when rotating your robot's arms: make sure that they do not strike and scratch other parts of its body. The robot should never be in contact with any liquids – even in vaporized form.

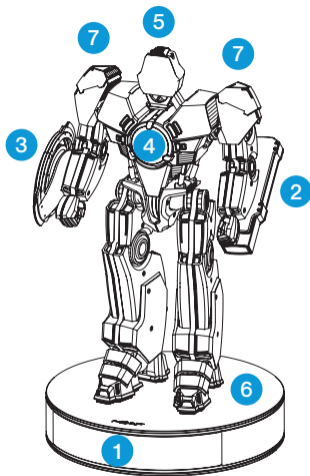

Please read the instructions contained in this booklet carefully in order to ensure a safe manipulation of your robot and watch.

Meet your robot

1. Push-to-open drawer
2. UV lamp
3. Magnifying glass
4. Thermometer
5. The crest / watch support
6. Robot base
7. Articulated arms - Each arm is articulated at three points: the shoulder, the elbow and the wrist.

### Important notices

Before manipulating your robot, please ensure that you are wearing gloves to avoid any scratches or marks. Please avoid any direct or close contact with the highly magnetic base when wearing a watch. A distance of 10cm should be kept.

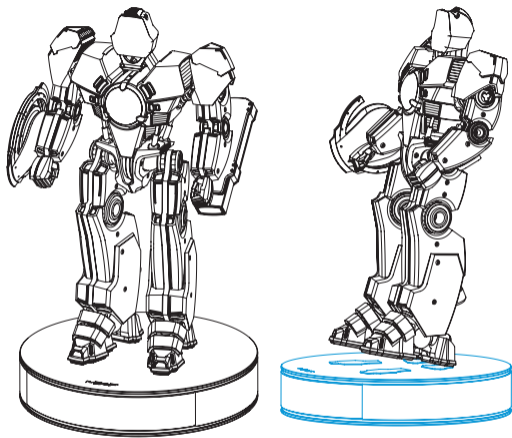

### Robot set-up

To place your robot on its base, hold the robot firmly by its hips, tilt it slightly backwards and place the back of its feet onto the dedicated spaces on the base. Slowly put the robot down – the strong magnets will pull it into place. Once your robot is set on the platform, place the lamp (see page 26) and magnifying glass (see page 28) on its arms.

### Robot removal

To remove your robot from its base, first remove the magnifying glass and the lamp and make sure that the robot is placed safely on an even surface. Then grasp the robot firmly by its hips and push it backwards whilst holding it securely, to free it from the magnets. Then lift the robot carefully from the base.

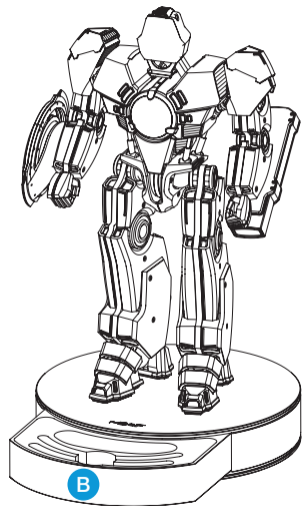
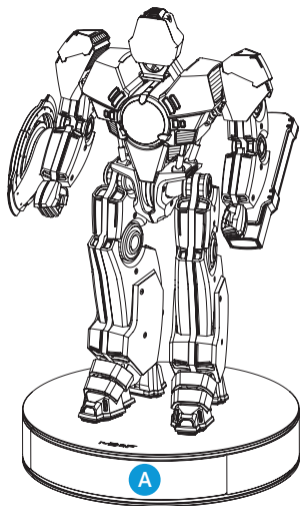

### Push-to-open drawer

The drawer located in the base of your robot is conceived to store your HM12 strap(s) and the cable to charge the robot's UV lamp. To use, press the drawer until you hear a clicking sound, then guide it until it is fully open. To close it, press the drawer again until you hear a clicking sound.

- A. Closed
- B. Open

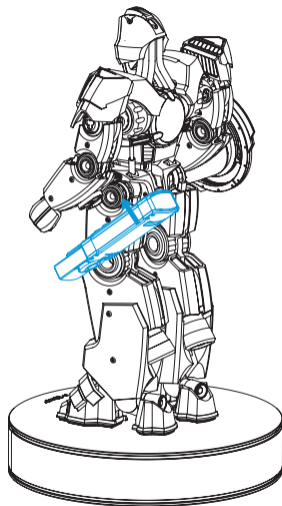
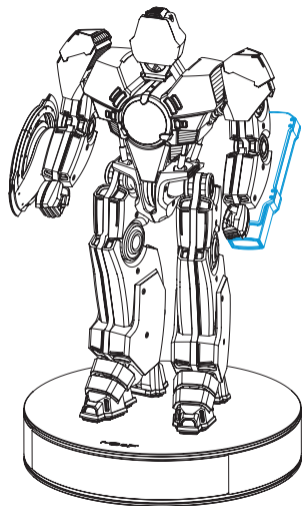

### Important information

The lamp should be handled carefully as it can fall easily on the robot's base and scratch it. Avoid applying pressure to the end of the torch, as the long lever arm could cause the object to fall. When moving the robot, remove the lamp prior to any manipulation.

### UV lamp

Your lamp features 3 settings; a standard lamp, a laser and a UV lamp setting. All are accessible and can be selected directly through the button placed on the wand. The lamp is attached to the arm by a magnet and can only be positioned in one direction. Be careful to hold it firmly when handling it to prevent it from falling onto the base.

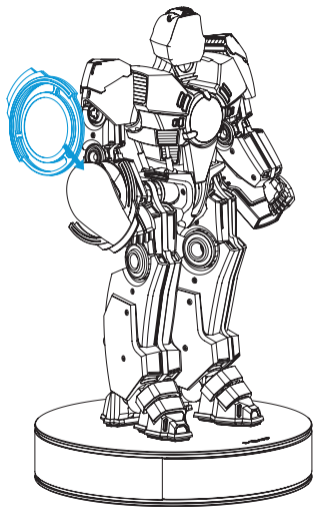

### Magnifying glass

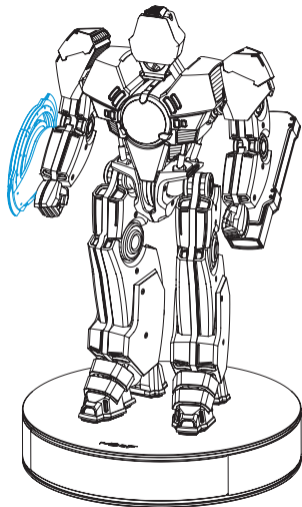

The magnifying glass simply slides out of the shield and is held in place by magnets at the bottom of its housing.

Care should be taken when sliding the magnifying in and out of the shield, to make sure it does not scratch the surrounding surfaces.

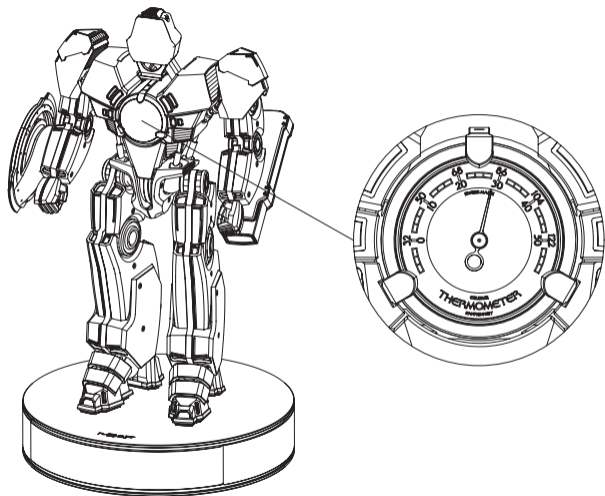

## Thermometer

Your robot is equipped with a mechanical thermometer with indications in both Celsius and Fahrenheit.

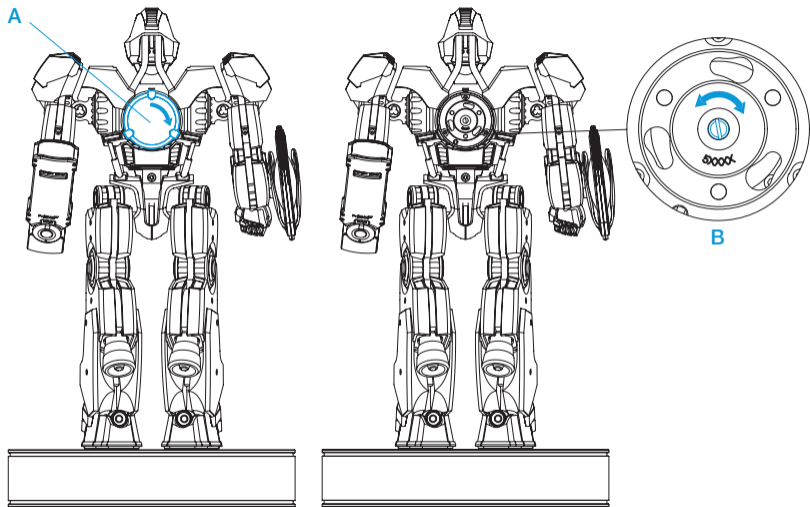

## Thermometer setup

To set and adjust the thermometer, face your robot from the back. Turn the central element (A) clockwise then pull it gently towards you. Using a screwdriver, set the hand's position by turning the screw above the serial number (B).

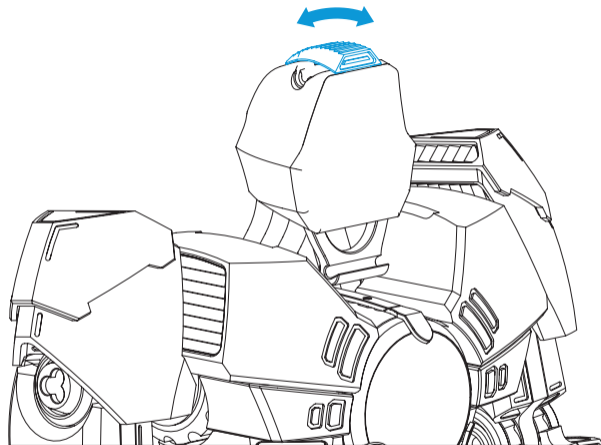

### Crest / watch support

The crest at the top of the robot's head slides back and forth, allowing the watch to be maintained correctly. Pull the crest backwards in order to place your watch on the robot's head.

Step 1: Remove the watch's strap with its quick release system (check page 14 for further information).

Step 2: Pull the crest backwards and maintain it.

Step 3: Place your watch's mobile attachment into the ridge; the bottom attachment should rest on the surface below. Care should be taken to make sure the watch is touching the soft black surface and does not scratch any surrounding metallic parts.

Step 4: Release the crest to lock the clip in place to secure the watch.

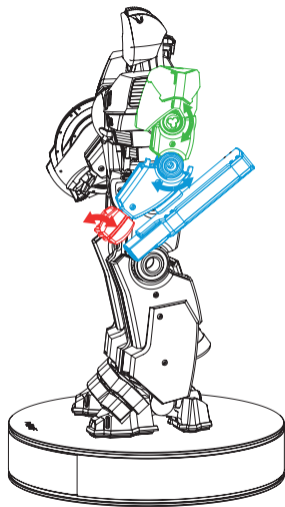
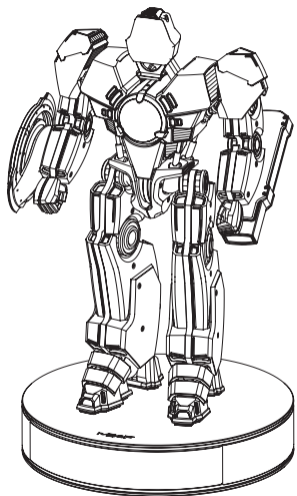

### Important information

Please always remove the lamp prior to adjusting or moving the arms of the robot to avoid it falling onto the base. The arms should be manipulated with care, and with gloves to avoid fingerprints that could alter the coating.

### Moving the arms

Each arm is articulated at three points: the shoulder, the elbow and the wrist.

[www.mbandf.com](http://www.mbandf.com)